

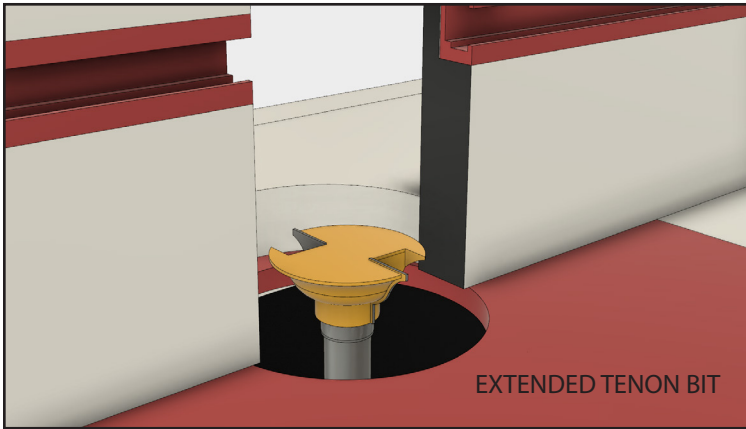

Build your own solid wood doors between 1-3/8" and 1-3/4" thick with the three-piece entry door router bit set. Follow the instructions below to make doors with extended mortise-and-tenon joints, or see the standard 12346 instructions.

Step 1: Set bit height.



To make a door with an extended tenon, install the shortest of the three bits in your router table instead of the standard coping bit.

Step 2: Set the fence.

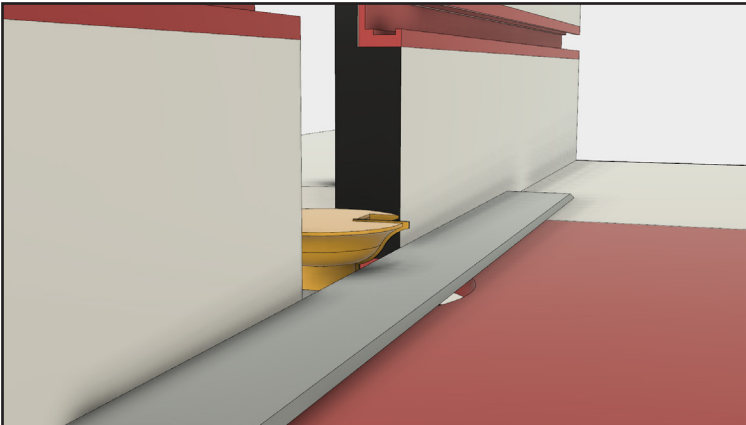

Set the fence flush with the narrowest part of the cutter at the bottom of the bit, just above the shank. Use a straightedge to align the fence with the cutting edge.

Step 3: Cope the ends of the rails.

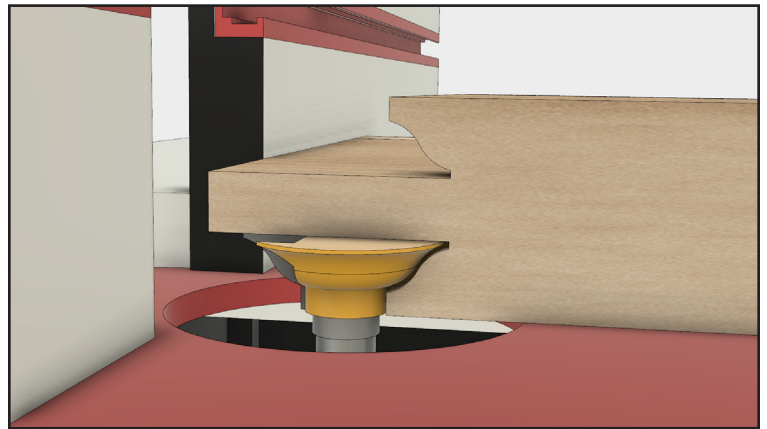

To cope the ends of a rail with extended tenons, route each end of the rail with the stock face down. Then flip the stock onto its opposite face and route both ends again.

Step 4: Install the profile cutter.

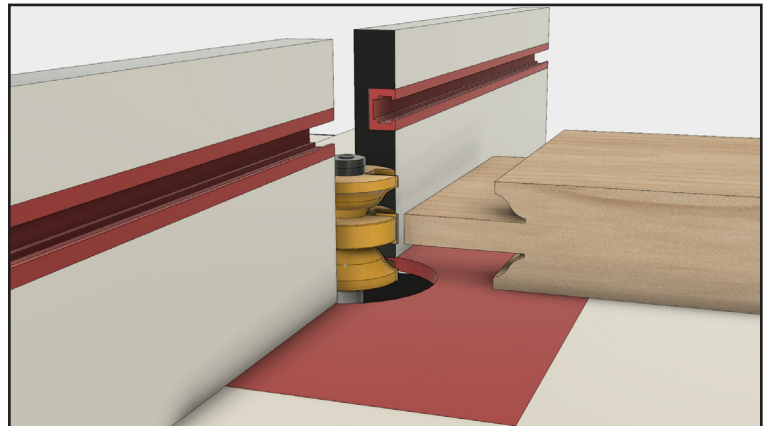

With the rails completed, you can replace the coping bit with the profile cutter. To set the bit height, place one of the coped rails on the router table and adjust the bit until it aligns with the profile in the end of the part.

Step 5: Position the fence.

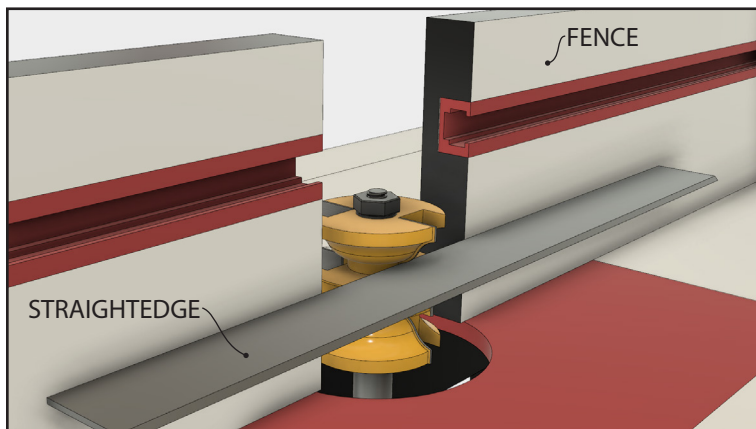

Use a straightedge to set the fence flush with the narrowest part of the profile cutter near the center of the bit and just above the straight cutter. Rotate the bit with your finger until it is perpendicular to the fence. Place the straightedge against the bit and pull the fence forward until it contacts the straightedge. Lock the fence in place.

Step 6: Route the profile.

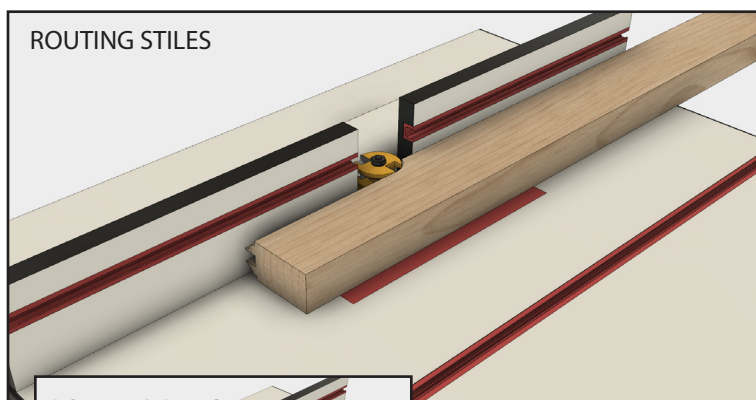

Before routing your stock, make a test cut in a piece of scrap the same thickness as your parts. Fit one of the rails with the test piece and adjust the router bit height if necessary. When the joint fits correctly, route the profile in your rails and stiles.

Tip: When making doors with more than two rails, be sure to route the profile into both long edges of the

Step 7: Cut the mortise-and-tenons

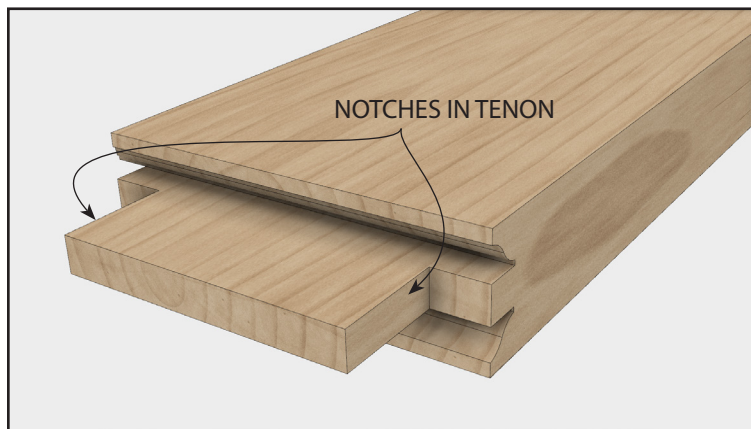

Notch both edges of the tenons in each rail and cut matching mortises in the stiles with a hollow chisel mortiser, router or mortising chisel.



Step 8: Assemble the door.

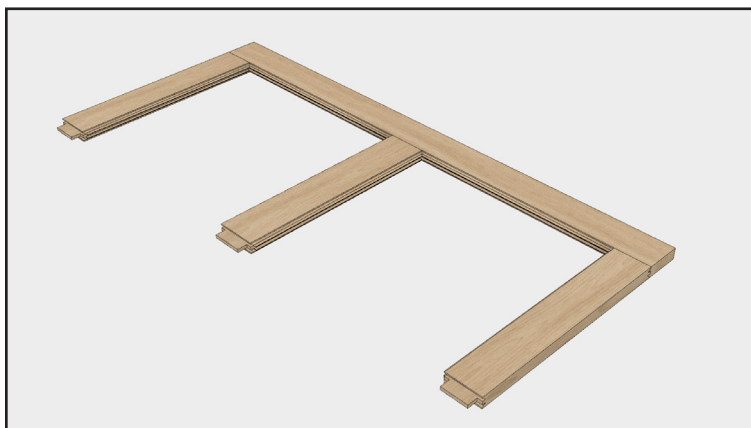

After routing the mortise-and-tenon joints, apply glue to all surface of the tenons and assemble the door. Insert the rails into one of the stiles as shown.

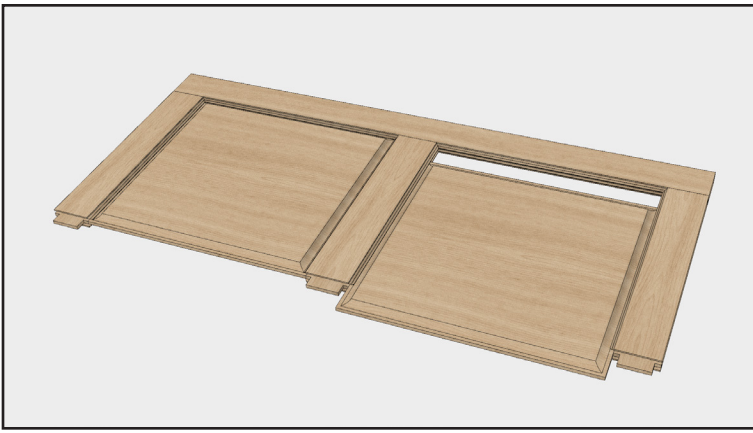

Slide the panels into place. Do not apply glue to any part of the panels.

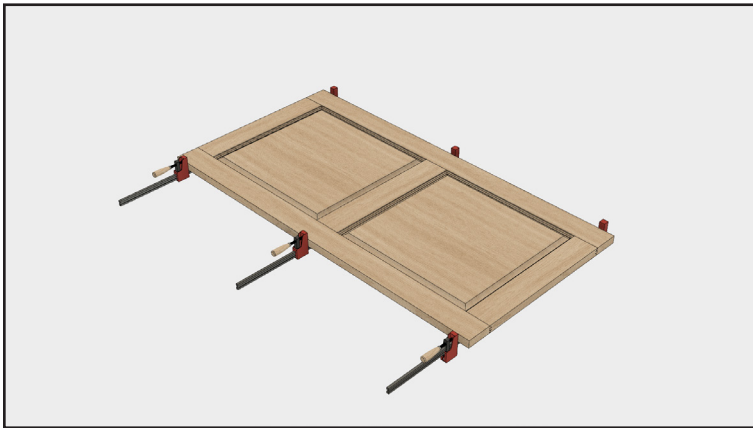

Clamp the door and allow the glue to dry. You should place one clamp under each rail to pull all of the joints together snugly.

